

Centre Number						Candidate Number				
Surname						Other Names				
Notice to Candidate. The work you submit for assessment must be your own. If you copy from someone else or allow another candidate to copy from you, or if you cheat in any other way, you may be disqualified.										
Candidate Declaration. I have read and understood the Notice to Candidate and can confirm that I have produced the attached work without assistance other than that which is acceptable under the scheme of assessment.										
Candidate Signature						Date				

For Examiner's Use	
Examiner's Initials	
Section	Mark
Section A Task 1 Q1	
Section A Task 2 Q1	
Section B Q1	
Section B Q2	
Section B Q3	
TOTAL	



General Certificate of Education
Advanced Subsidiary Examination
June 2014

Physics (Specifications A and B)

PHA3/B3/X

Unit 3 Investigative and Practical Skills in AS Physics
Route X Externally Marked Practical Assignment (EMPA)

Section B Written Test

For this paper you must have <ul style="list-style-type: none"> your completed Section A Task 2 question paper / answer booklet. a ruler a pencil a calculator. 	Instructions <ul style="list-style-type: none"> Use black ink or black ball-point pen. Fill in the boxes at the top of this page. Answer all questions. You must answer the questions in the space provided. Do not write outside the box around each page or on blank pages. Show all your working. Do all rough work in this book. Cross through any work you do not want to be marked.
Time allowed <ul style="list-style-type: none"> 1 hour 15 minutes 	Information <ul style="list-style-type: none"> The marks for questions are shown in brackets. The maximum mark for this paper is 25.
Details of additional assistance (if any). Did the candidate receive any help or information in the production of this work? If you answer yes, give the details below or on a separate page. Yes <input type="checkbox"/> No <input type="checkbox"/>	

Practical Skills Verification Teacher Declaration: I confirm that the candidate has met the requirement of the practical skills verification (PSV) in accordance with the instructions and criteria in section 3.8 of the specification.	Yes <input type="checkbox"/>
--	-------------------------------------

Signature of teacher Date

As part of AQA's commitment to assist students, AQA may make your coursework available on a strictly anonymous basis to teachers, examining staff and students in paper form or electronically, through the Internet or other means, for the purpose of indicating a typical mark or for other educational purposes. In the unlikely event that your coursework is made available for the purposes stated above, you may object to this at any time and we will remove the work on reasonable notice. If you have any concerns please contact AQA.

To see how AQA complies with the Data Protection Act 1988 please see our Privacy Statement at aqa.org.uk.

Section B

Answer **all** the questions in the spaces provided.

Time allowed 1 hour 15 minutes.

You will need to refer to the work you did in Section A Task 2 when answering these questions.

1 (a) (i) Determine the gradient, G , of your graph (**Figure 11**).

.....

.....

$G =$

1 (a) (ii) Determine the intercept, I , on the vertical axis of your graph.

[3 marks]

.....

.....

$I =$

1 (b) In part (a)(i) of Section A Task 2 you measured ϵ , the emf of the power supply. It can be shown that

$$\frac{\epsilon}{V} = \frac{r}{R} + 1,$$

where V and R are as defined in Section A Task 2, and r is the internal resistance of the power supply.

State and explain how your graph can be used to determine r .

[3 marks]

.....

.....

.....

.....

.....

.....

.....

1 (c) (i) What assumption is being made **about the voltmeter** when it is used to measure ε ?

.....

.....

.....

1 (c) (ii) In part (a)(ii) of Section A Task 2 you measured V_x , the voltmeter reading when resistor X was in parallel with the $68\ \Omega$ resistor and switch S was closed. Explain why V_x is less than ε .

.....

.....

.....

1 (c) (iii) Evaluate $\frac{GV_x}{\varepsilon - V_x}$.

[4 marks]

.....

.....

$$\frac{GV_x}{\varepsilon - V_x} = \dots\dots\dots$$

<hr style="width: 50%; margin: 0 auto;"/> 10

Turn over for the next question

Turn over ►

- 2 A student performs a different experiment to investigate how the pd across a power supply changes as the resistance of the external circuit is varied.

The internal resistance, r , of the power supply is unknown.

The student begins by measuring the emf of the power supply and then connects an increasing number of $22\ \Omega$ resistors across the supply, measuring the pd as each resistor is added.

This procedure is illustrated in **Figure 12**.

Figure 12

measuring the emf

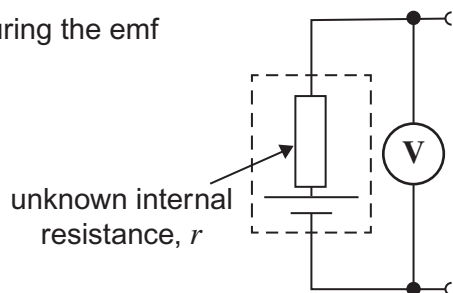

measuring the pd
with one $22\ \Omega$
resistor connected

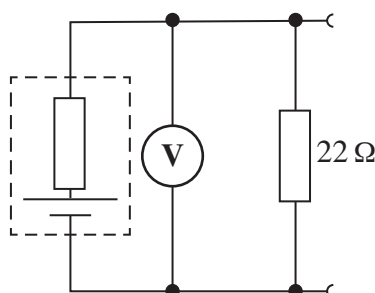

measuring the pd
with two $22\ \Omega$
resistors connected

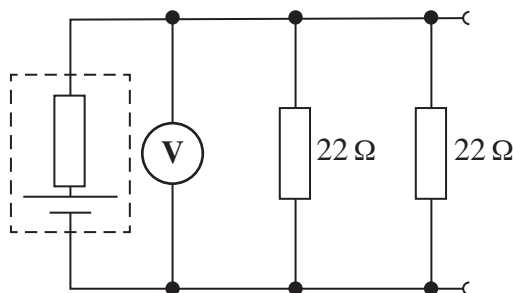

The student continues with this procedure until twenty resistors have been connected to the circuit.

Some of the student's results, showing how V , the pd across the power supply, depends on n , the number of $22\ \Omega$ resistors connected to the circuit, are shown below.

n	V/V
0	1.56
1	1.33
2	1.16

n	V/V
4	0.92
7	0.71
12	0.51

- 2 (a)** Plot these data on **Figure 13** below then use your graph to predict V_{20} , the pd across the power supply when $n = 20$.

[2 marks]

$$V_{20} = \dots\dots\dots$$

Figure 13

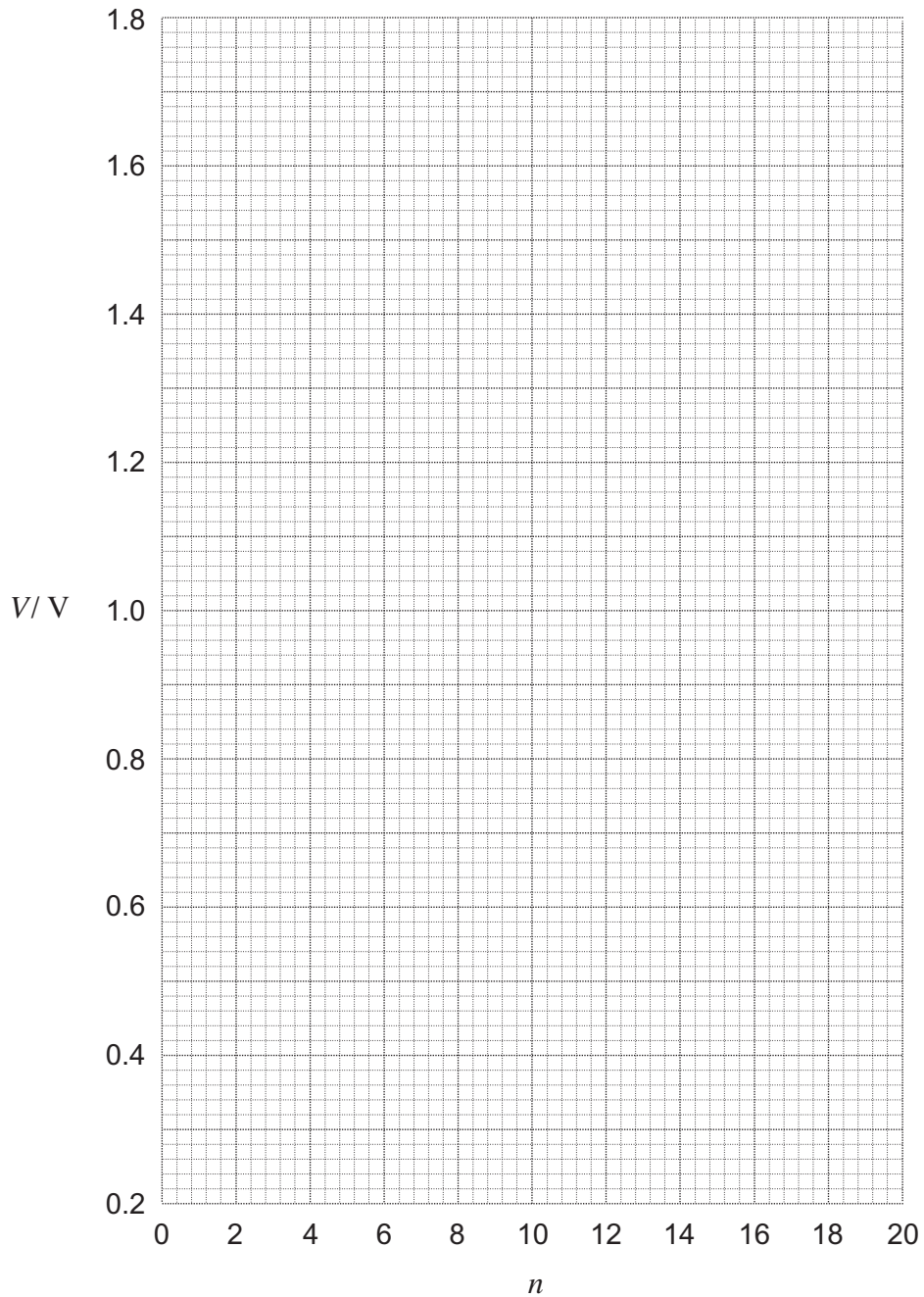

Turn over ►

- 2 (b) The student uses a computer spreadsheet to analyse how P , the power dissipated in the external resistance, produced by the $22\ \Omega$ resistors, depends on n . **Figure 14** shows P for values of n between 4.0 and 8.0.

Figure 14

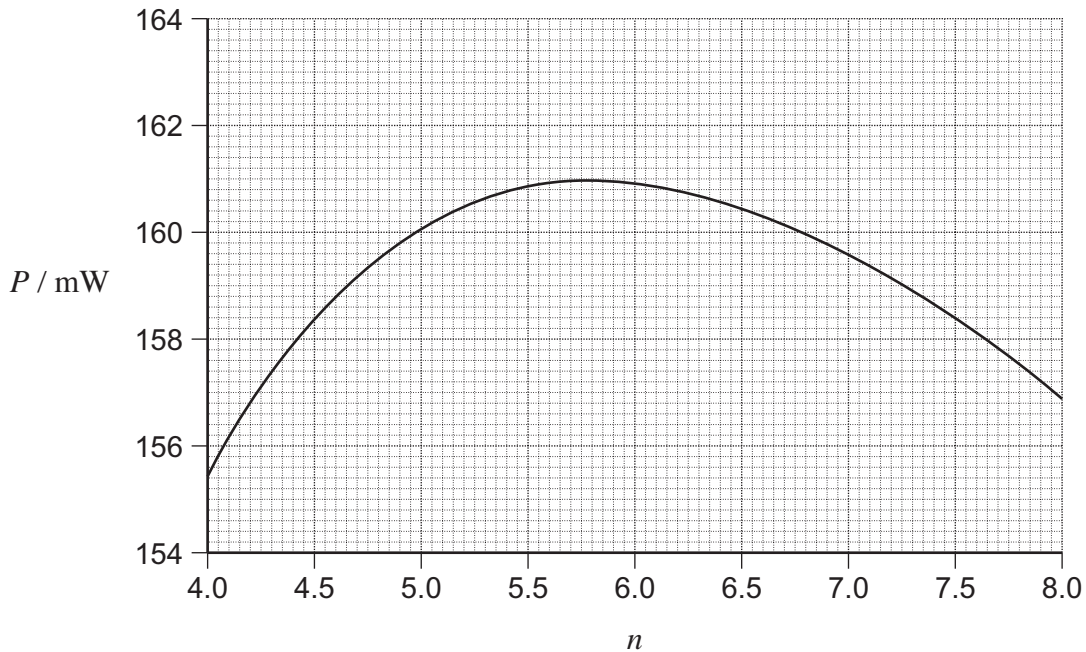

The student finds that P has a maximum value when the external resistance is equal to the internal resistance of the power supply.
Use **Figure 14** to determine the internal resistance of the power supply in the student's analysis.

[3 marks]

.....

.....

.....

.....

.....

.....

.....

.....

- 3 A student devises an ohm-meter based on an analogue milliammeter. The student's circuit is shown in **Figure 15**.

Figure 15

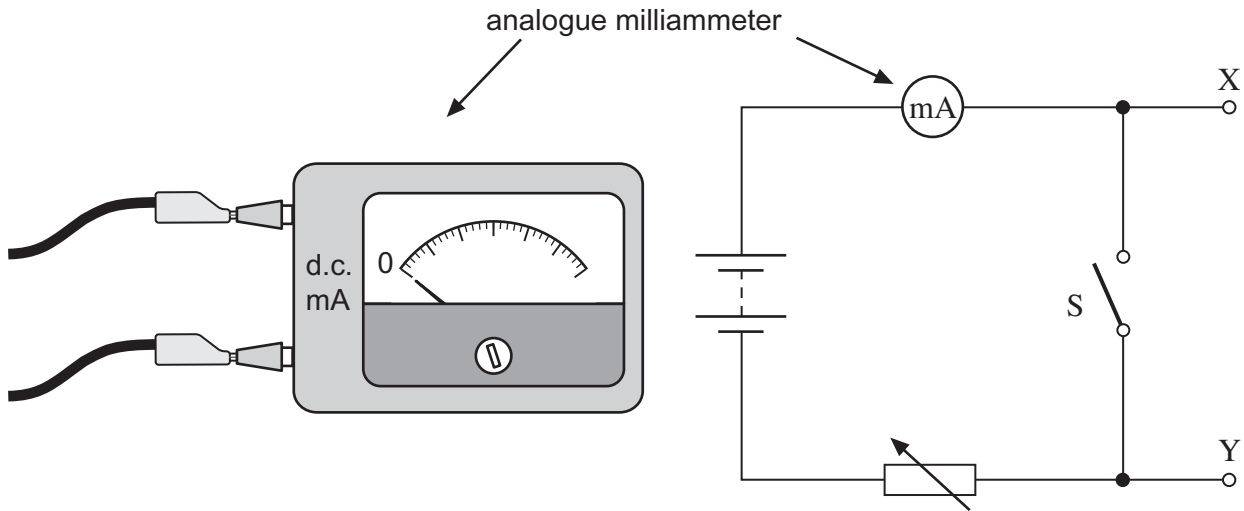

The principle of the student's ohm-meter is that the meter reading decreases when any resistor is connected between X and Y. The amount by which the reading decreases depends on the resistance between X and Y.

The procedure for using the circuit is as follows:

- Step 1 The variable resistor is set to maximum resistance. Switch S is then closed and the meter indicates a small current, as shown in **Figure 16a**.
- Step 2 The resistance of the variable resistor is reduced until the meter shows the full-scale reading, as shown in **Figure 16b**.
- Step 3 A resistor is connected between X and Y and switch S is opened. The reading on the meter falls to a value less than full-scale, as is shown in **Figure 16c**.

Figure 16a

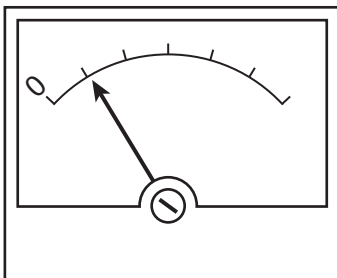

Figure 16b

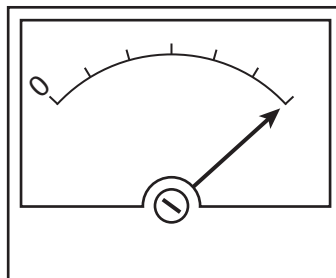
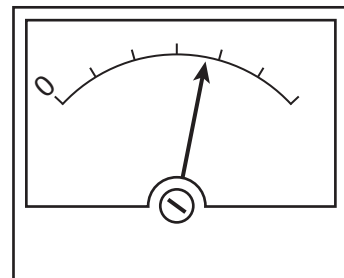

Figure 16c



Turn over ►

- 3 (a) (i) Having carried out steps 1 and 2, explain what the student should do next to calibrate the scale on the meter to read resistance.

[3 marks]

.....

.....

.....

.....

.....

.....

- 3 (a) (ii) The emf of the battery decreases over time.
State what effect, if any, this change will make to the **resistance** readings made in **Figure 16b** and in **Figure 16c** when the procedure is correctly followed.

[2 marks]

Figure 16b

.....

Figure 16c

.....

- 3 (b) Commercially produced analogue ohm-meters have scales similar to that shown in **Figure 17**.

Figure 17

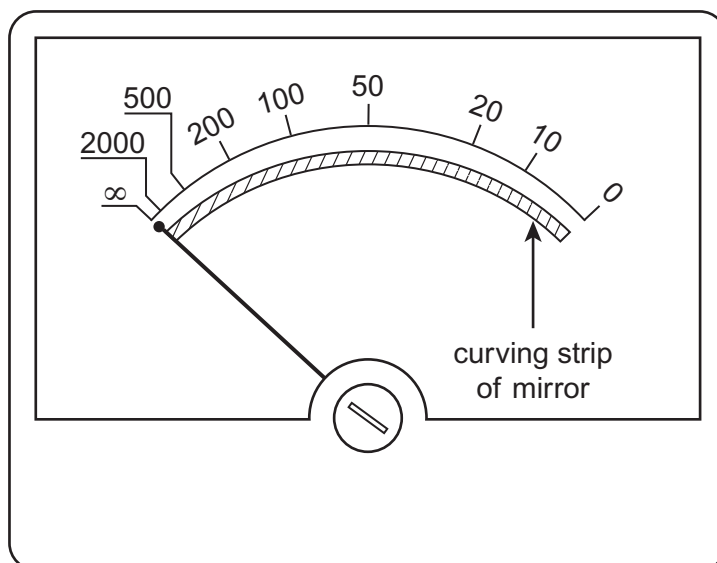

3 (b) (i) State a difficulty you might experience in reading this type of scale and explain why this difficulty arises.

[2 marks]

.....

.....

.....

.....

.....

3 (b) (ii) **Figure 17** shows that the meter has a curving strip of mirror mounted behind the needle, close to the scale. State and explain how this mirror can be used to reduce random error in reading the meter.

[2 marks]

.....

.....

.....

3 (b) (iii) State and explain how the uncertainty in the measurements made on this scale depends on the resistance of the resistor connected to the meter.

[1 mark]

.....

.....

.....

END OF QUESTIONS

10

There are no questions printed on this page

**DO NOT WRITE ON THIS PAGE
ANSWER IN THE SPACES PROVIDED**

There are no questions printed on this page

**DO NOT WRITE ON THIS PAGE
ANSWER IN THE SPACES PROVIDED**

There are no questions printed on this page

**DO NOT WRITE ON THIS PAGE
ANSWER IN THE SPACES PROVIDED**